

JAREK 1S 155

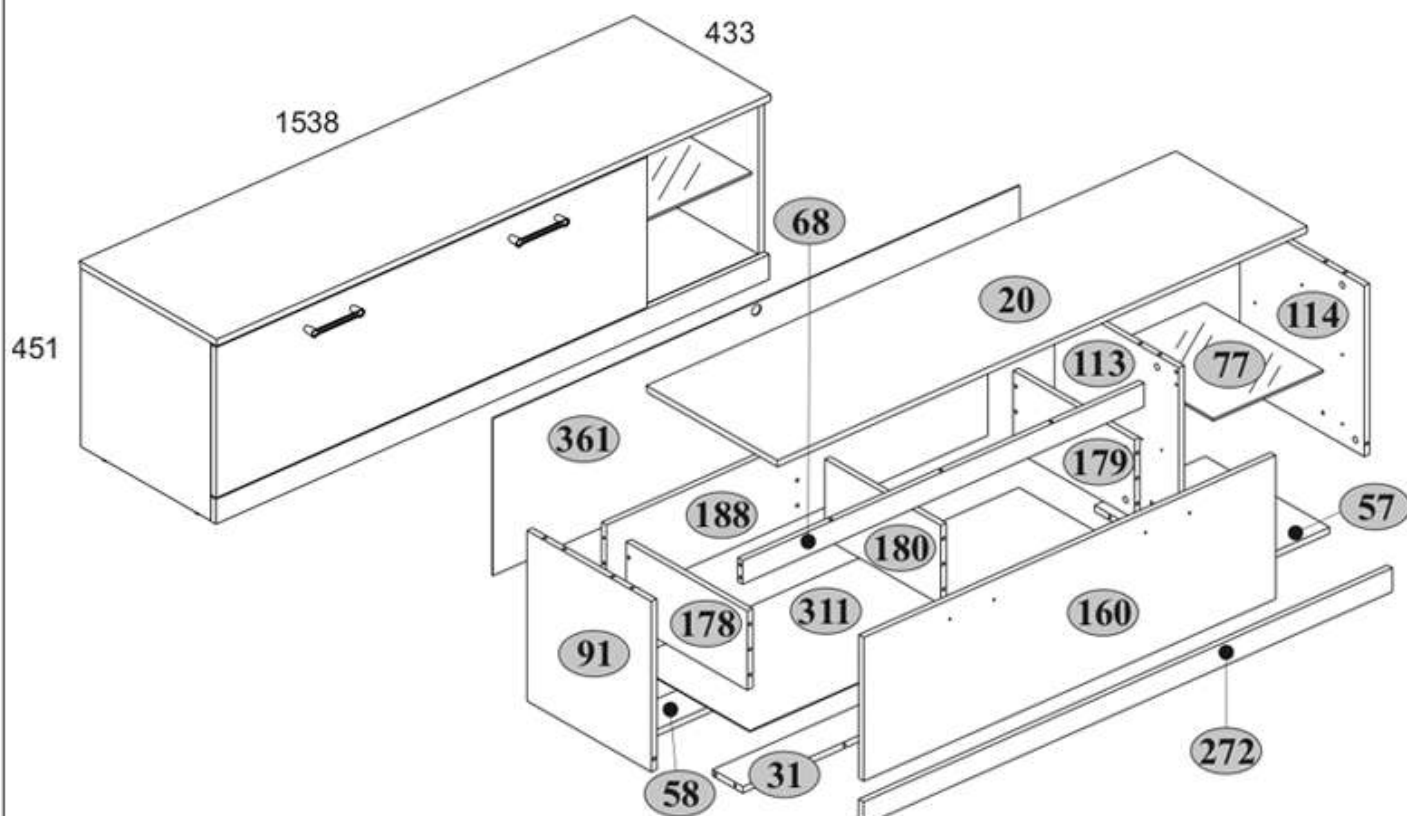

ŠTEVILO	DOLŽINA	ŠIRINA	GLOBINA	ŠTEVILO KOSOV	PAKIRANJE
20	1538	433	16	1	2/2
31	1166	100	16	1	2/2
57	322	410	16	1	1/2
58	1166	100	16	1	2/2
68	1166	60	16	1	1/2
77	319	390	6	1	2/2
91	431	410	16	1	1/2
113	431	410	16	1	1/2
114	431	410	16	1	1/2
160	1196	363	16	1	2/2
178	400	200	16	1	1/2
179	400	200	16	1	1/2
180	383	200	16	1	1/2
188	1108	200	16	1	2/2
272	1536	60	16	1	2/2
311	1138	405	2,5	1	1/2
361	1532	397	2,5	1	1/2

Navodila za uporabo

Priporočljivo je, da ob nakupu razpakiranega izdelka v trgovini preverite njegovo kakovost in popolnost. Izdelek je treba sestaviti tako, kot je opisano v tem priročniku.

Medtem ko je izdelek v uporabi, je treba občasno zategniti ohlapne vijačne spoje.

Če je treba premikati predmete po stanovanju, morate pred premikanjem izdelek popolnoma sprostiti z bremena (ležišča). Da bi preprečili poškodbe obstoječih nosilcev, je treba izdelek pred premikanjem dvigniti. Pohištvo ne sme biti izpostavljeno stiku z vodo.

Brisanje prahu na izdelku je treba opraviti z rahlo vlažno mehko krpo.

Da bi preprečili deformacijo delov in spremembo barve izdelkov, pohištva ne nameščajte na neposredno sončno svetlobo.

Medtem ko je izdelek v uporabi, je **PREPOVEDANO**:

- nameščati pohištvo v bližini grelnih naprav, blizu surovih sten in v prostorih z relativno vlažnostjo več kot 70 %;
- segrevati elementov pohištva na temperaturo, višjo od 40 C;
- med sestavljanjem in uporabo kompleta izdelkov stopati na vodoravne ščite in okna;
- uporabljati kemičnih čistil za čiščenje pohištva.

Garancija proizvajalca

1. Garancijski rok za uporabo izdelka - 18 mesecev od datuma prodaje. V garancijskem roku proizvajalec zagotavlja popravilo ali zamenjavo izdelkov, če uporabnik ni kršil pravil uporabe.
2. Reklamacije mora potrošnik vložiti neposredno pri trgovski organizaciji, v kateri je bilo pohištvo kupljeno, pri čemer mora predložiti "Navodila za uporabo " in kopijo potrdila o prodaji.
3. Izdelek, ki je del kompleta, izpolnjuje zahteve državni standardi 16371-2014, TR TS 025/2012.
4. Življenjska doba pohištva - 5 let.
5. Proizvajalec si pridržuje pravico do sprememb v zasnovi izdelka, ne da bi pri tem ogrozil njegove zahteve glede zasnove in uporabe.
6. Za sestavljanje izdelkov je priporočljivo vključiti usposobljeno osebje.

To je pomembno! Navodila shranite za primer ponovne montaže pohištva ali reklamacije. Pri uveljavljanju reklamacije uporabite zapis iz navodila.

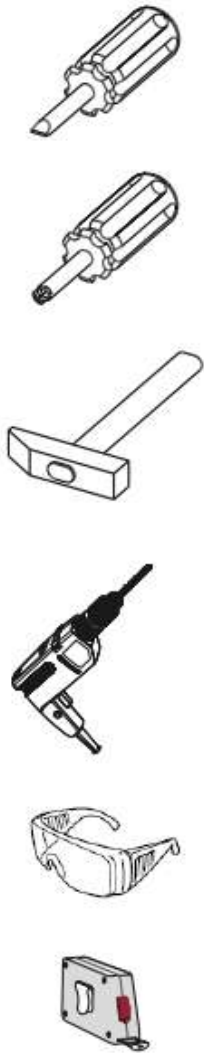

A1 27	A2 27	B5 10x50 1
C1 8x35 26	G 1,5x26 40	H27 2
I 1	L3 400 2	M4 M4x22 4
N1 6	P4 4	Q 2
R102 3,5x16 6	R3 3x20 16	R24 7x50 6
R27 5,0x13 12	S5 8	S8 2
U 1	Z12 400 1	

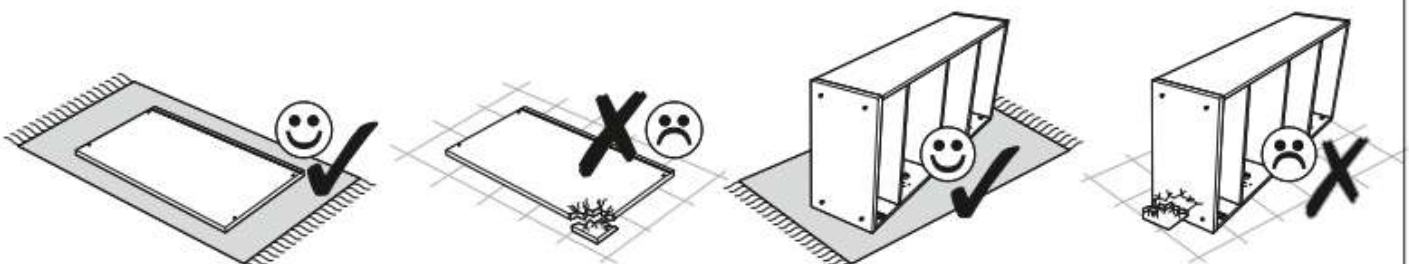
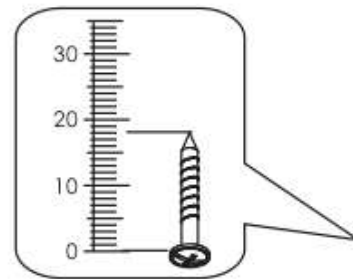
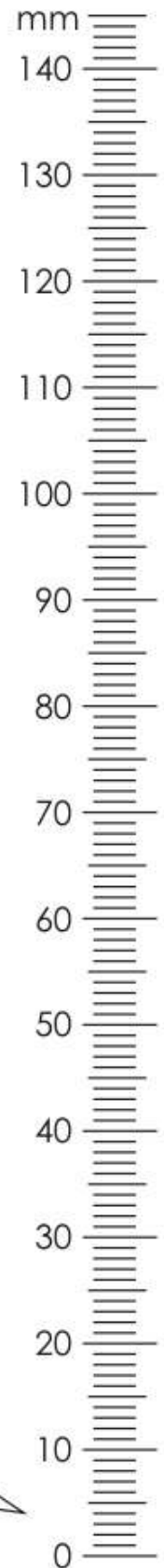

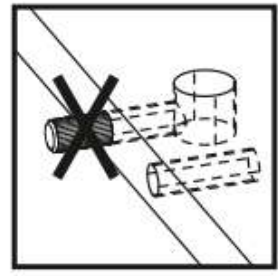
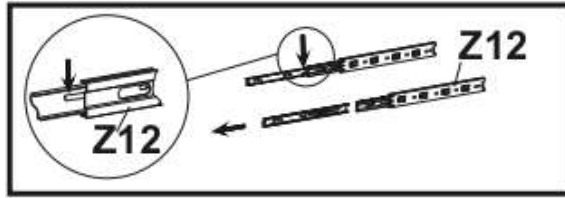
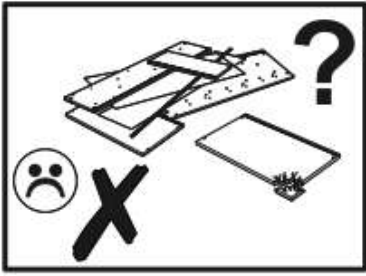

1

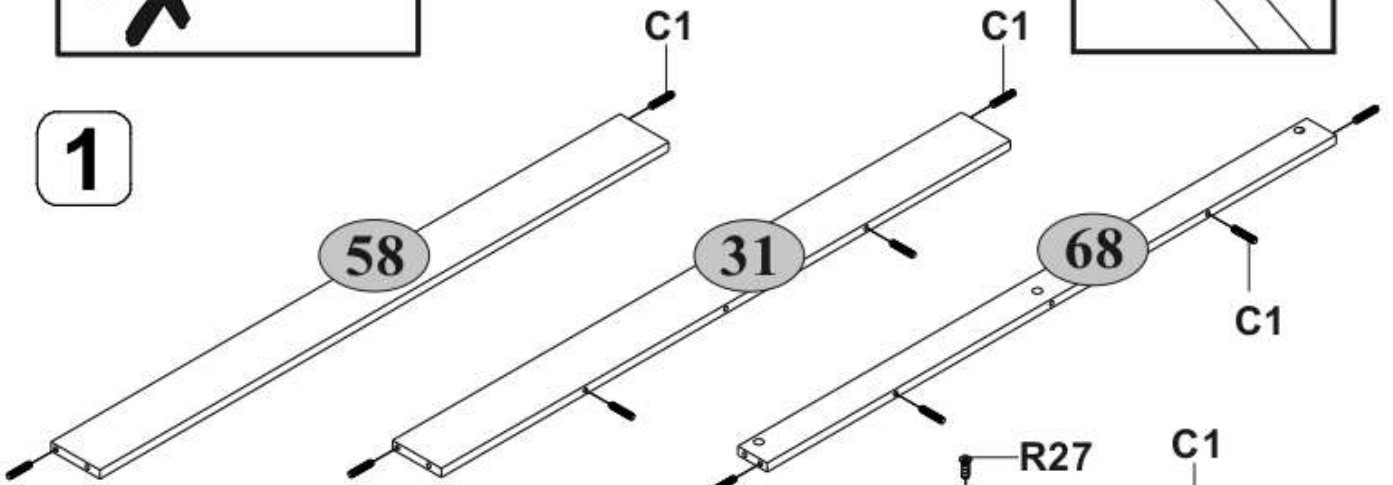

2

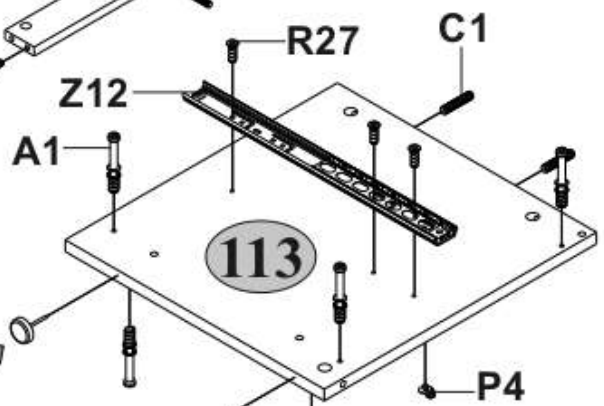

3

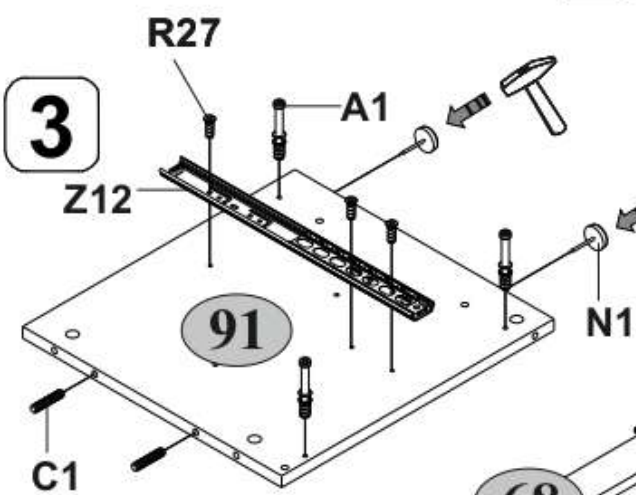

4

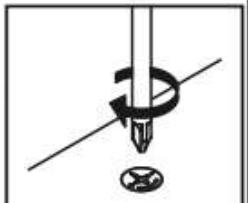
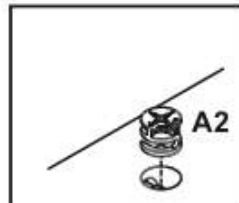
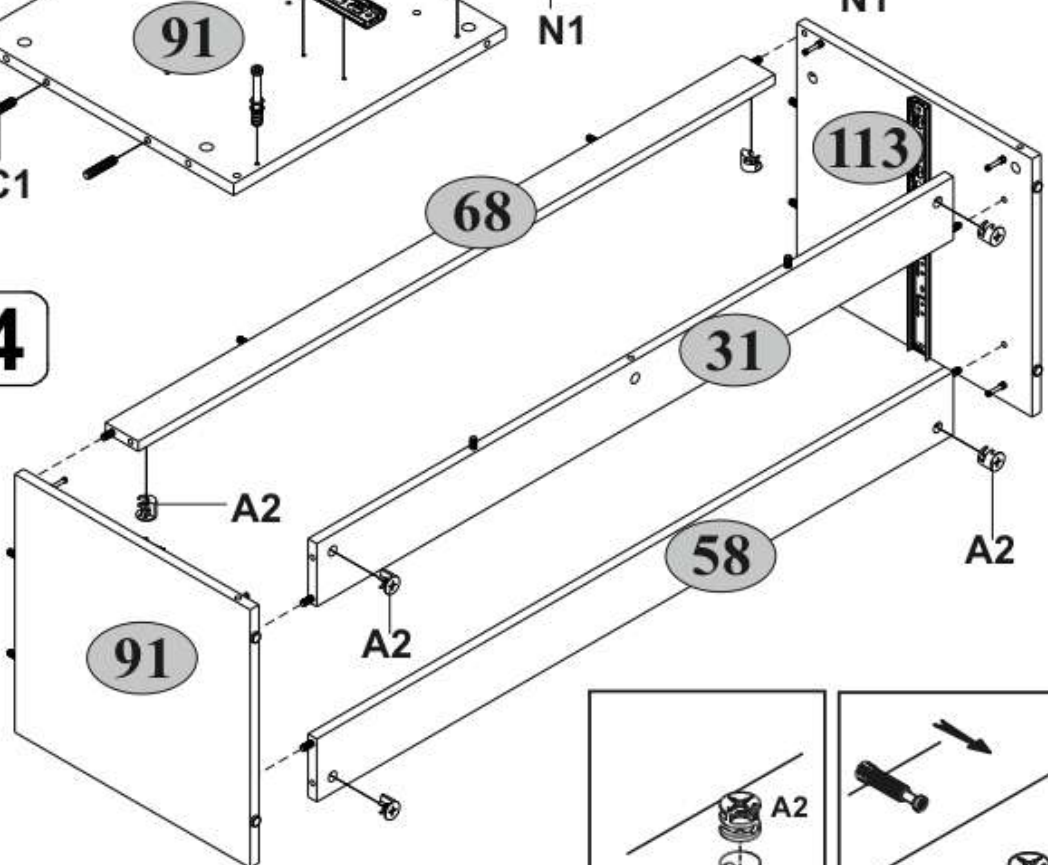

5

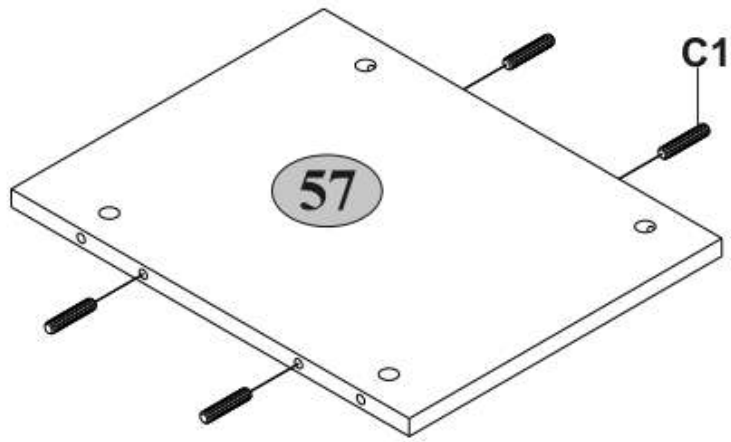

6

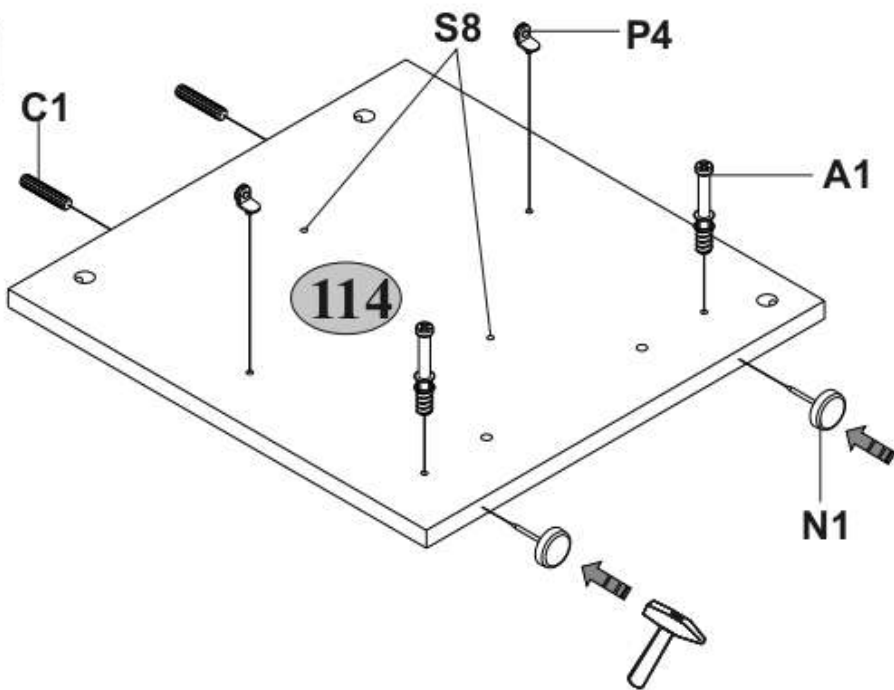

7

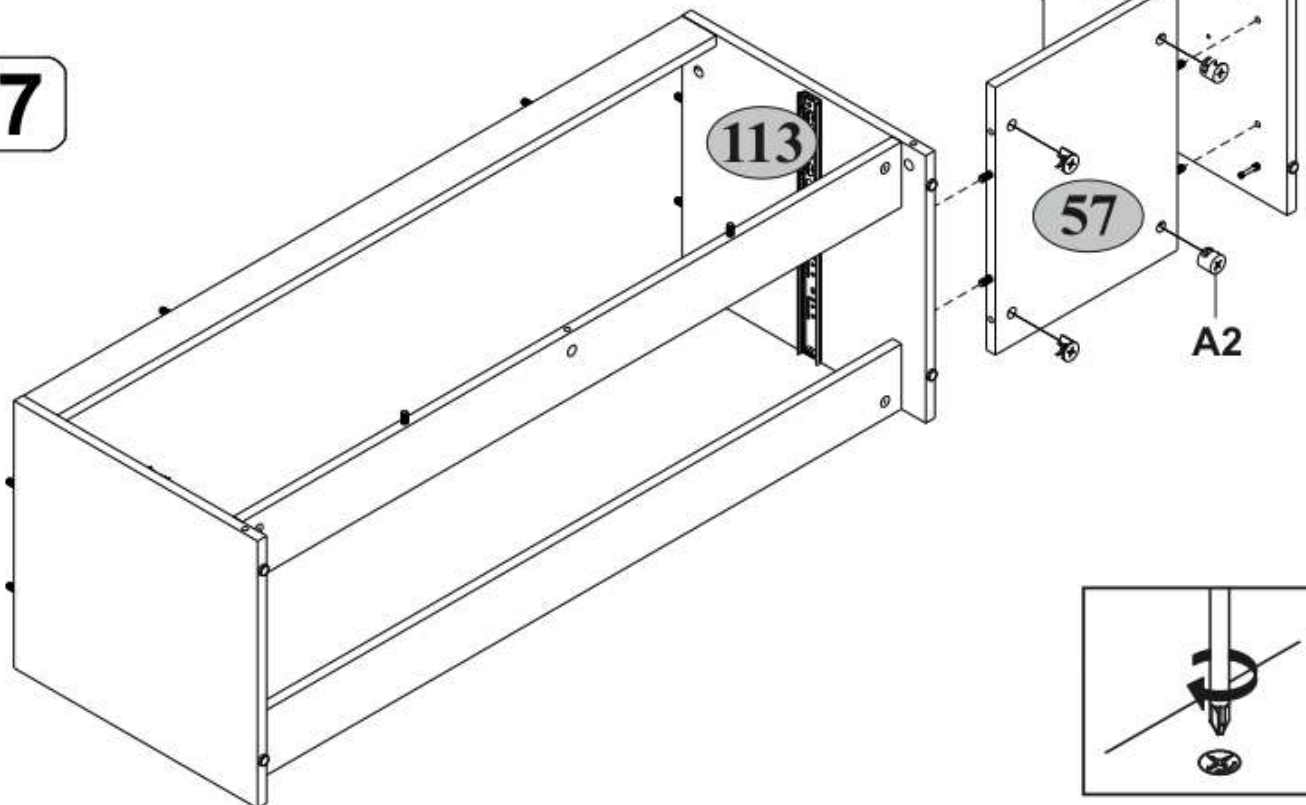

8

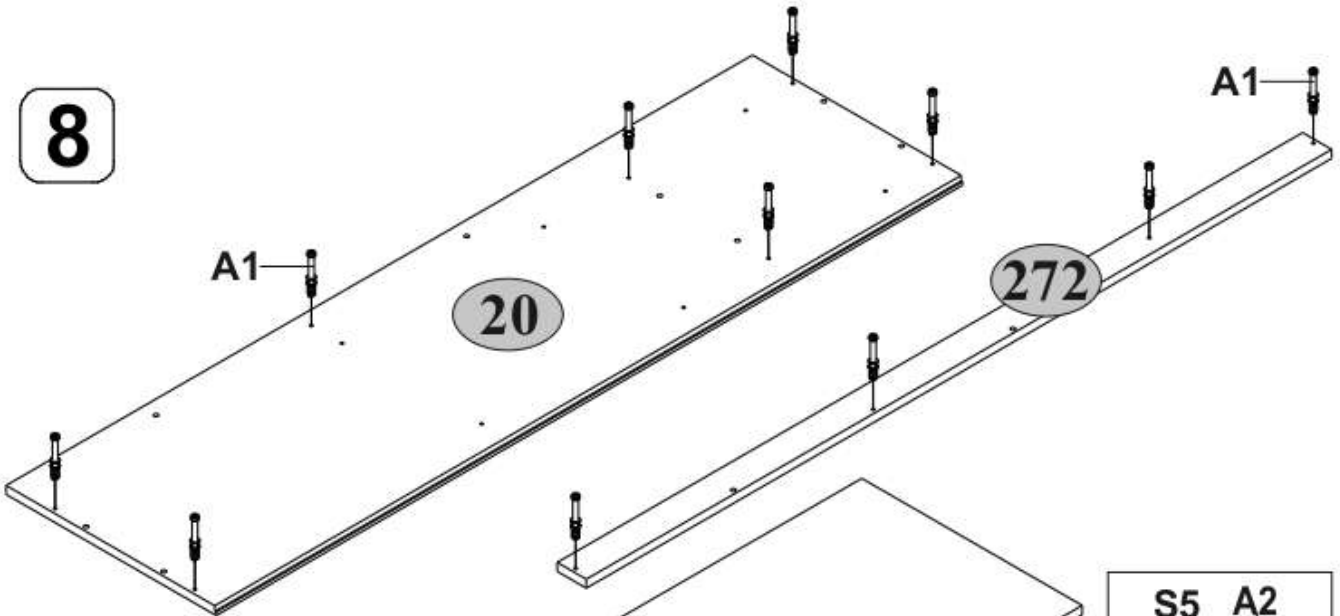

9

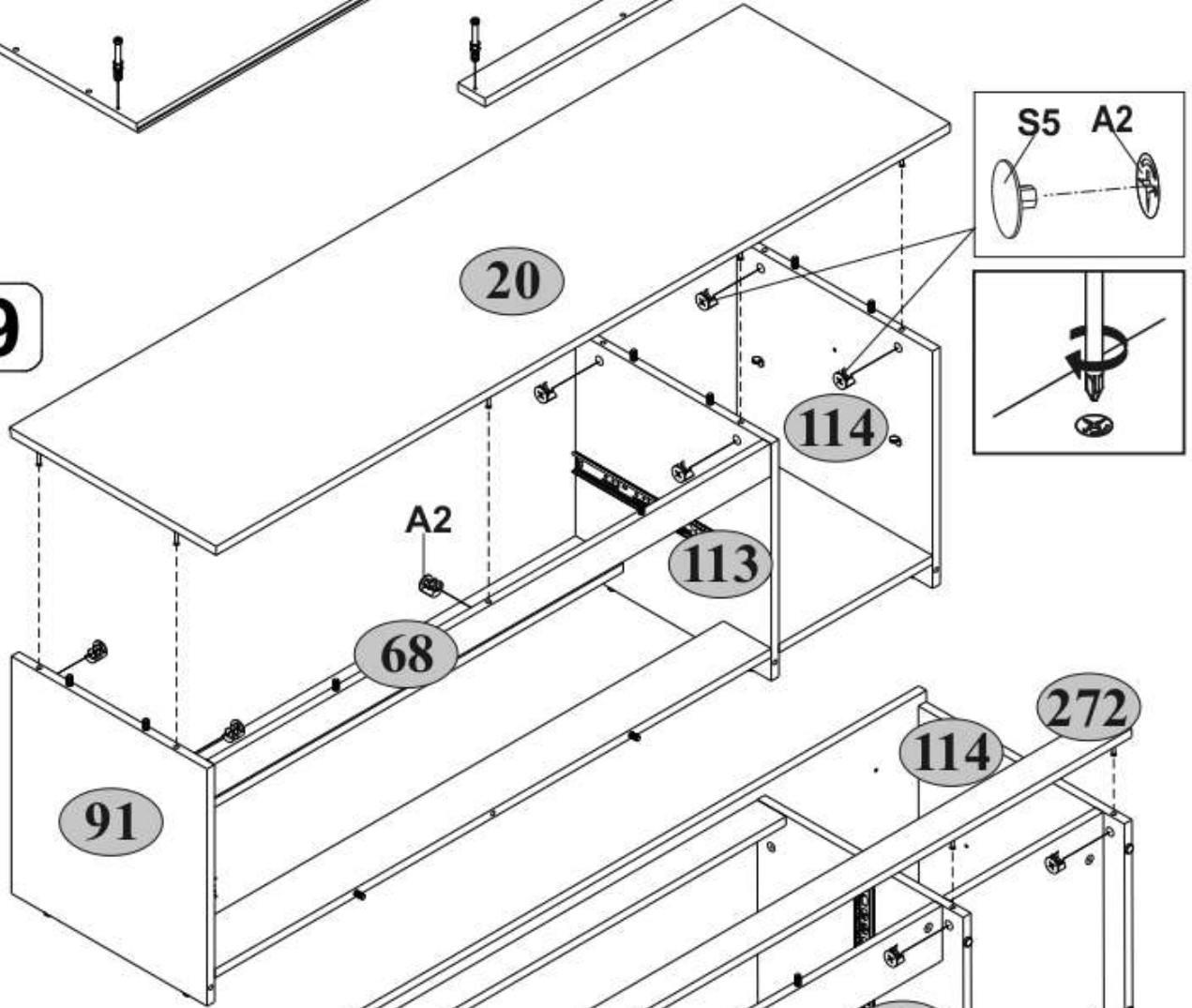

10

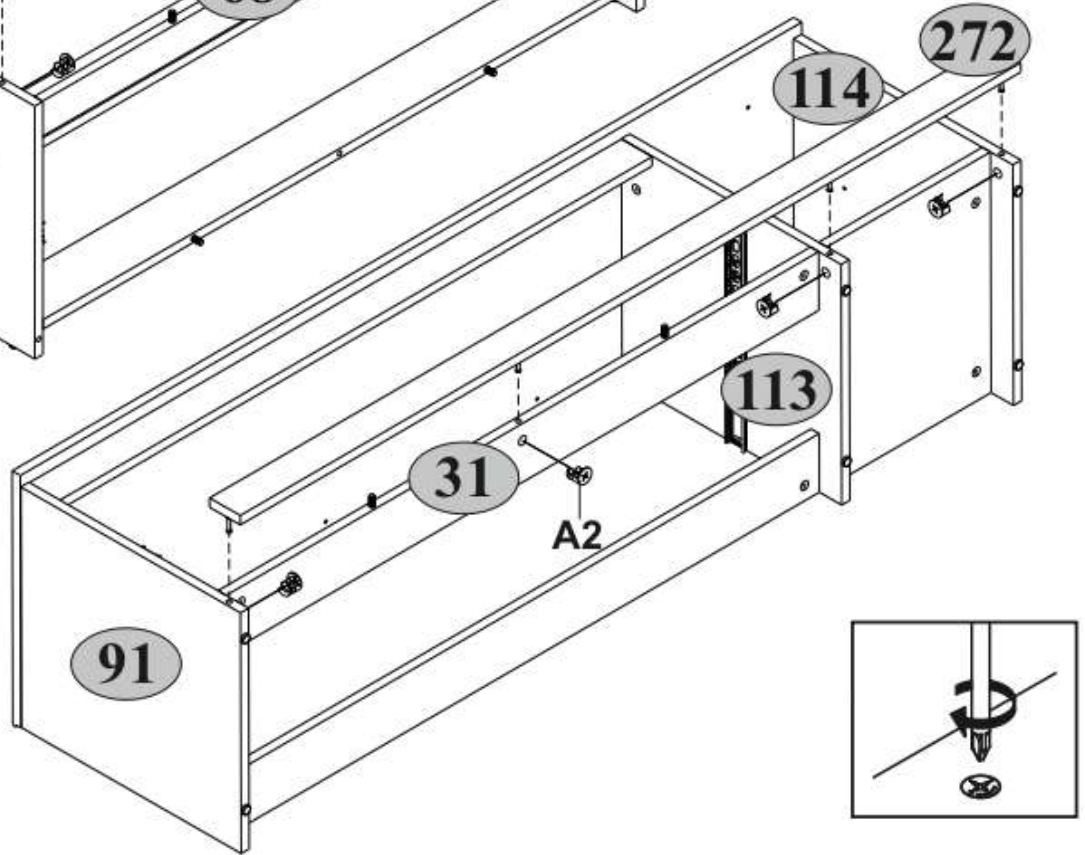

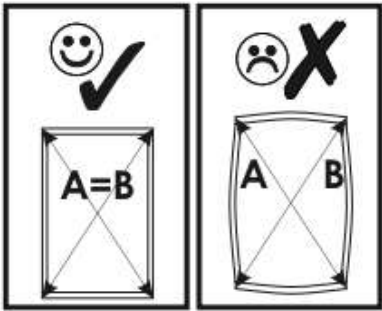

11

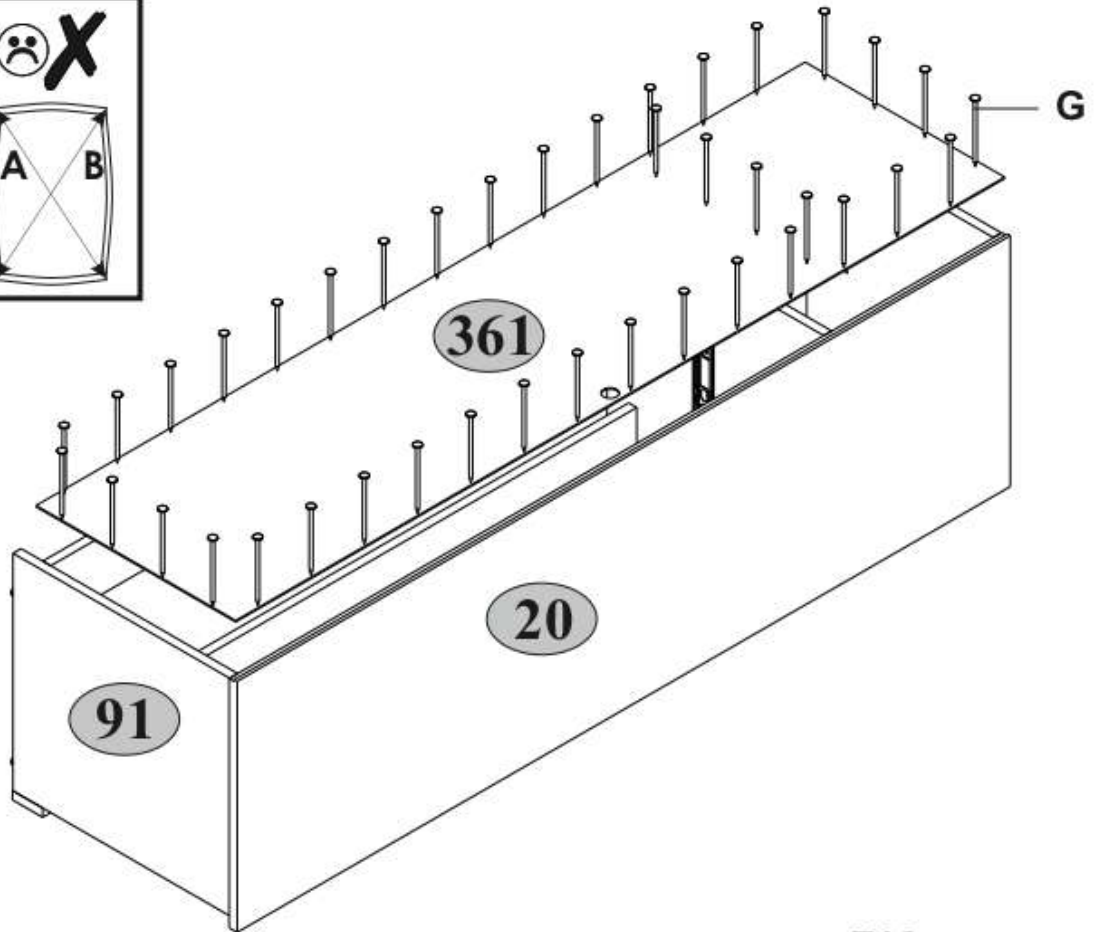

12

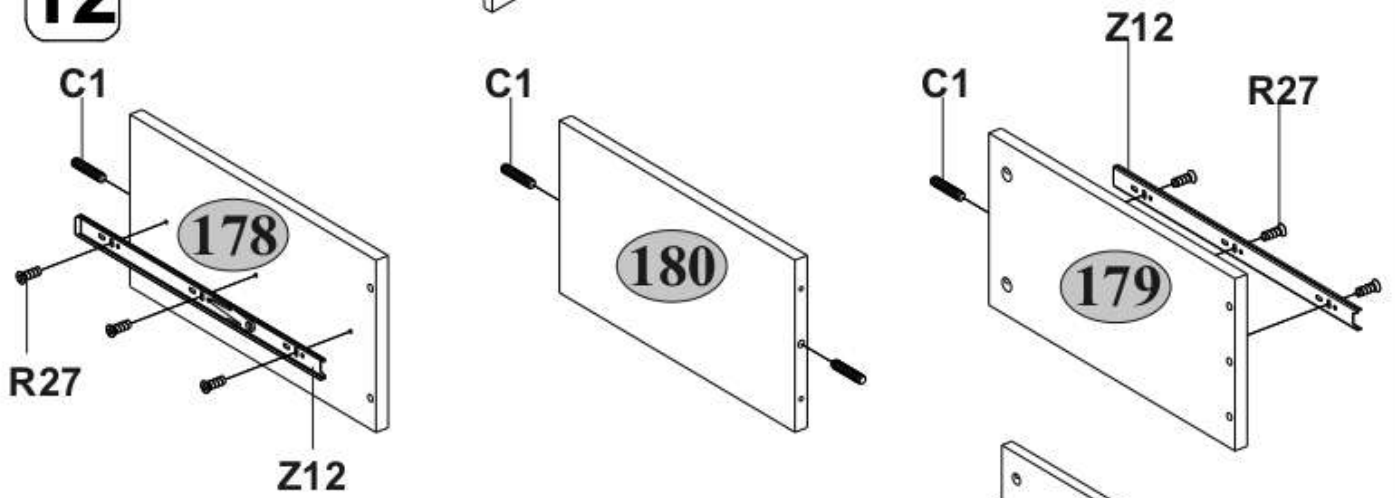

13

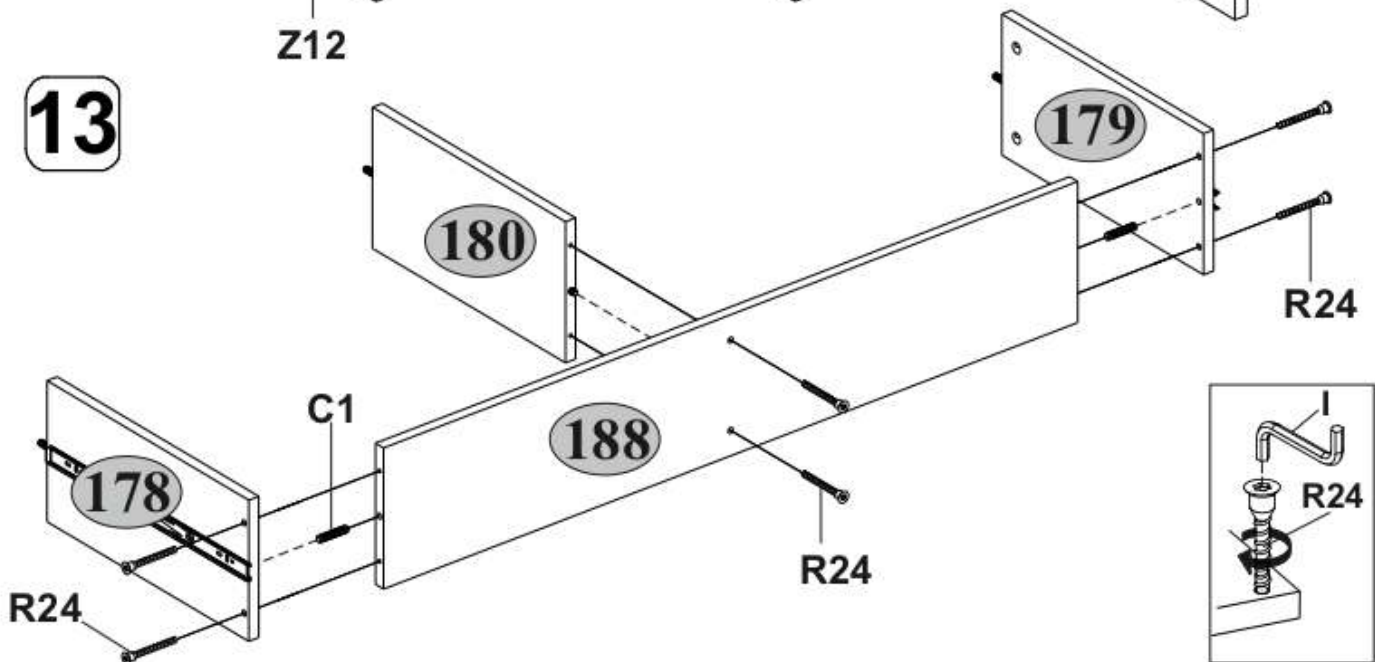

14

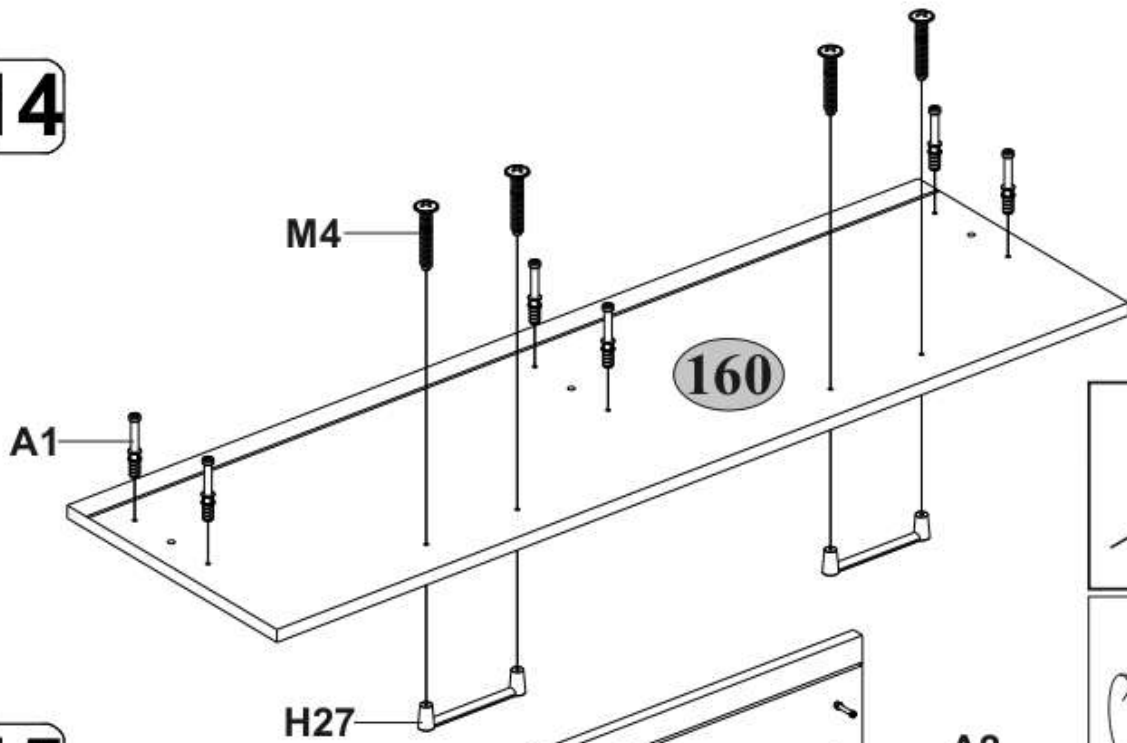

15

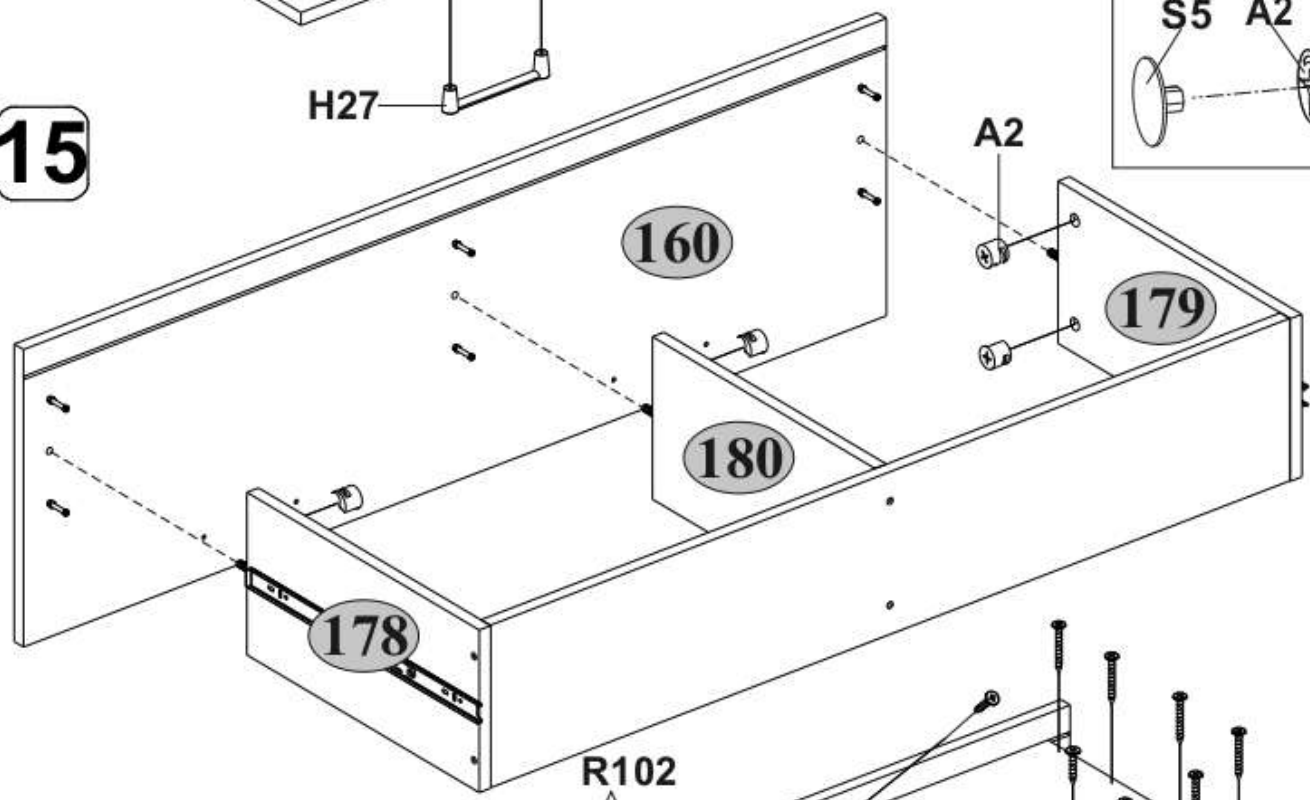

16

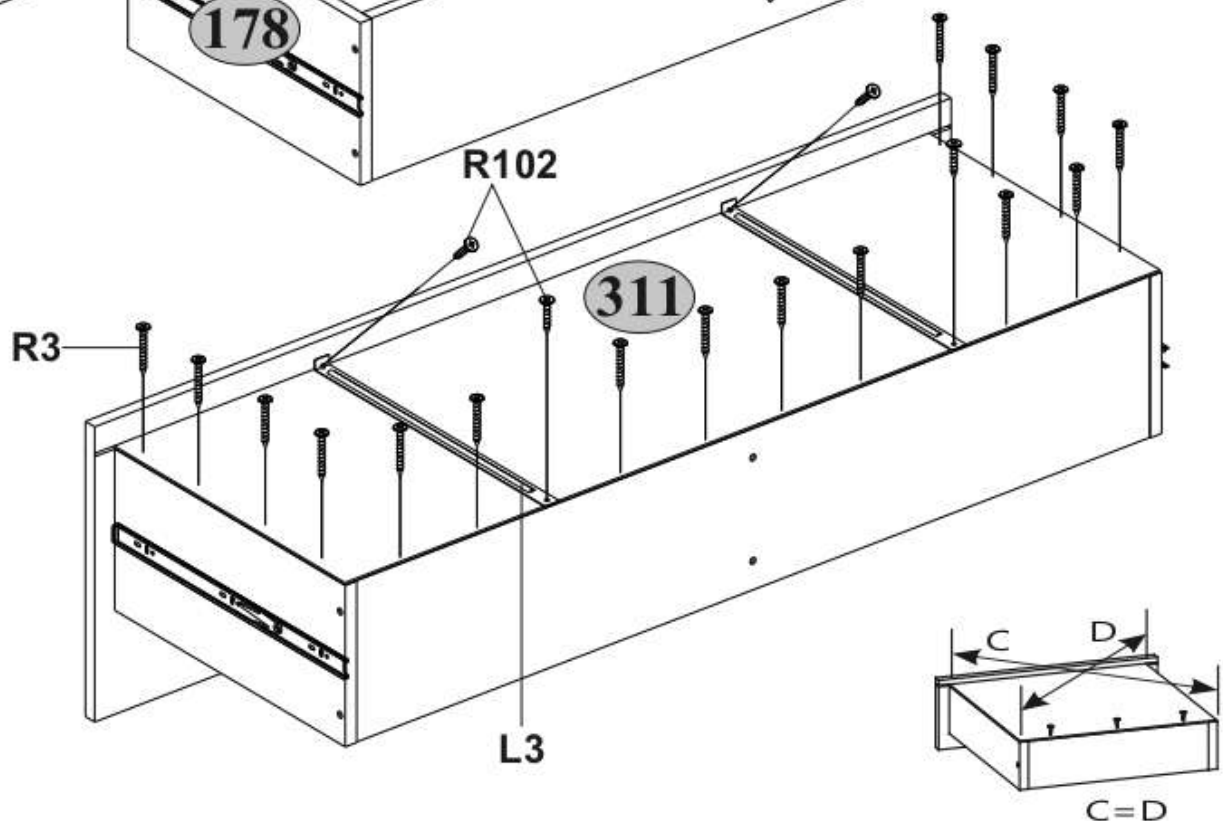

17

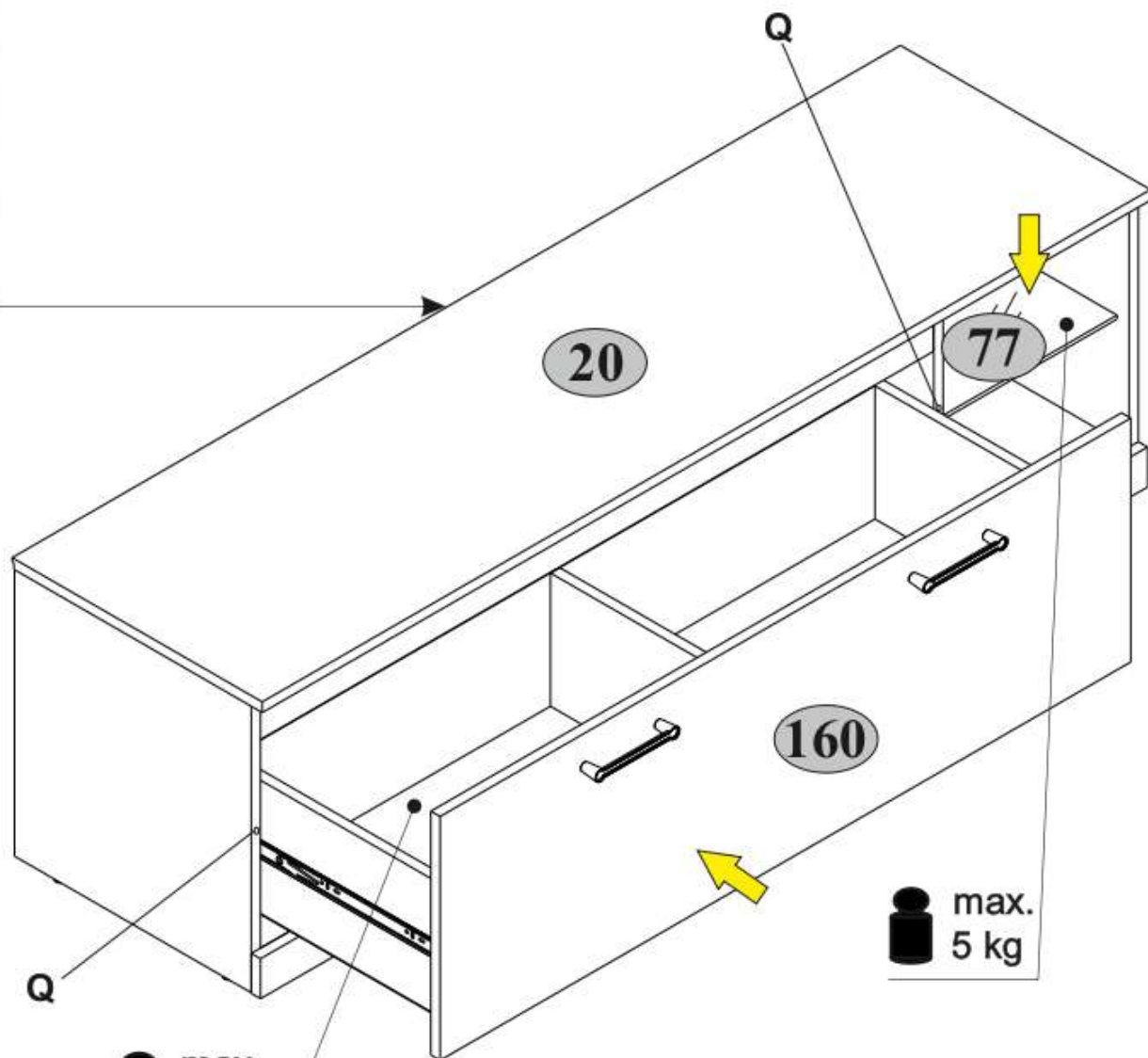
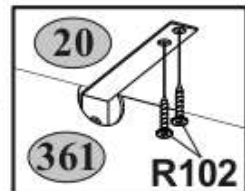
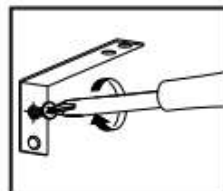
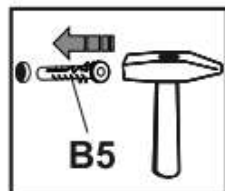
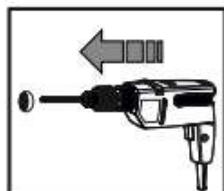
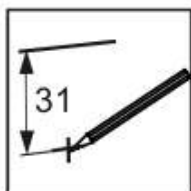
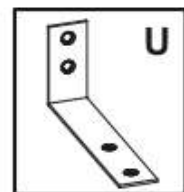
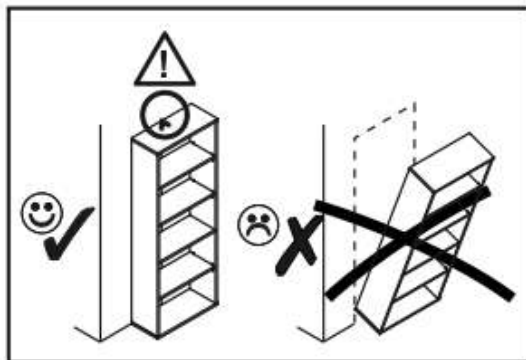

 max. 8 kg

 max. 5 kg